



# Model: SC-300 (230v models)

## Electric Woodchip-Burning Stationary Rack Smoker

### Approximate Smoker Capacities

(Capacities will vary based on physical shape, weight, and method of loading for each product specified.)

	<u>Standard</u>	<u>Max.</u>
Pork Butts (8-10 lbs)(3.6 - 4.5 kg) each.....	30 pieces	30 (5 racks)
St. Louis Ribs (2.75 lbs)(1.2 kg) each.....	25 pieces	50 (10 racks)
w/Optional vertical rib racks.....	65 pieces	65 (5 racks)
Whole Chicken (3-4 lbs)(1.4 - 1.8 kg) each....	40 pieces	56 (7 racks)
Beef Brisket (12-15 lbs)(5.4 - 6.8 kg) each.....	10 pieces	14 (7 racks)



(20) rack slides, 1 1/2" (38mm) spacing  
 16.25 ft<sup>2</sup> (1.51 m<sup>2</sup>) standard cooking surface (5 racks)



### Standard Features:

- 304 series stainless steel construction; exterior and interior.
- Mineral wool insulated cabinet.
- Front locking swivel casters and rear non-locking swivel casters.
- Convection fan with 8" (203mm) blower wheel.
- Control with a digital cook and hold thermostat ((80° to 325°F)(27° to 163°C)), allows for selection of cook temperature, cook time, hold temperature and independent control of each smoke element).
- Dual smoker elements and woodchip boxes.
- 4" (102mm) grease drain pan.
- (5) 18" x 26" (457 x 660mm) nickel chrome plated product racks (see illustration above).

### Optional Features:

- Right hand door hinge.
- Internal meat probe system. Allows the control to be programmed to cook until the internal temperature of the product reaches the set temperature, instead of cooking for a set cook time.
- Steam system. Steam element replaces one smoke element and a 2 1/2" (64mm) steam pan holds water. Steam can be turned on or off, along with turning the smoke element on or off.
- Stainless steel product racks.
- (5) nickel chrome plated vertical rib racks. Replaces the standard product racks. Each vertical rib rack holds 13 slabs of ribs for a total capacity of 65 slabs of ribs.
- Stainless steel vertical rib racks.

Southern Pride Distributing, LLC  
 401 S Mill St  
 Alamo, TN 38001  
 Phone: 731.696.3175  
 Fax: 731.696.3180  
 www.southernpride.com

REVISED: February 2022 Revision 2  
 An ongoing program of product improvement may require us to change specifications without notice.

Serial number: C3000055 to Current

© 2019 Southern Pride Distributing, LLC

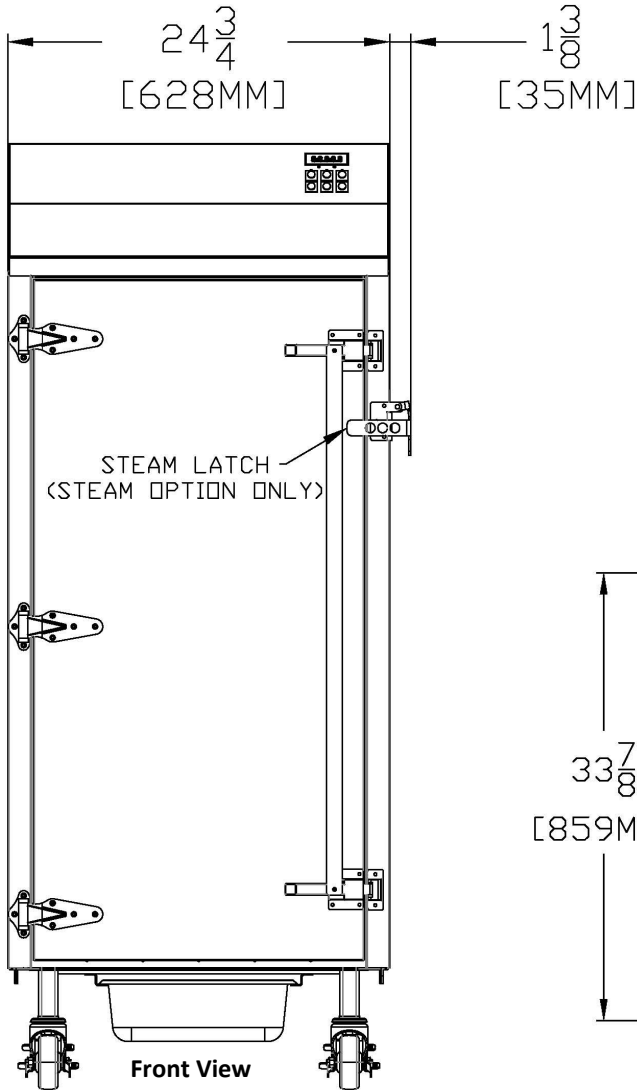

# Model: SC-300 (230v models)

## Electric Woodchip-Burning Stationary Rack Smoker

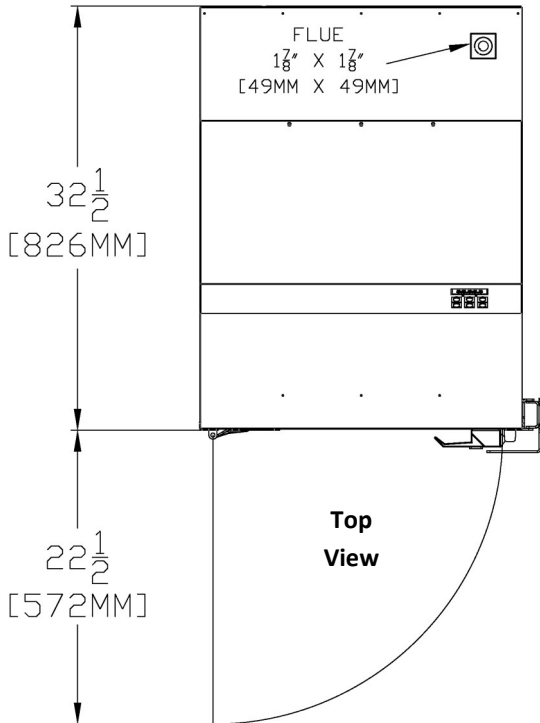
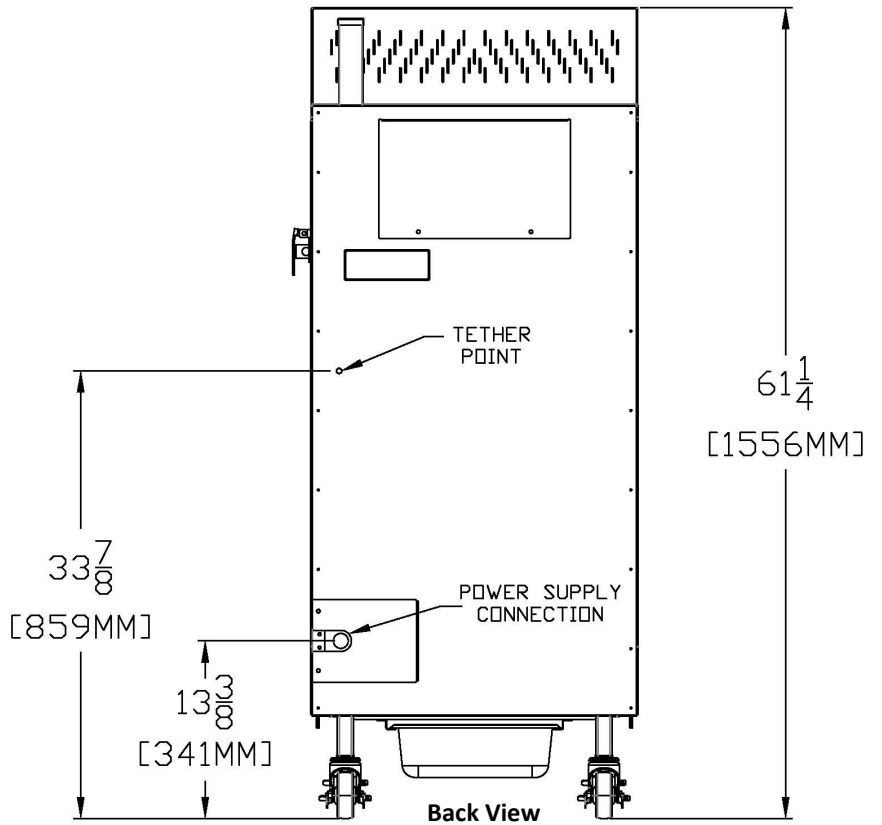

Standard leg locations (center to center) -  
19 1/2"W x 27 3/4"D (496 x 704mm)

### REQUIREMENTS

#### ELECTRICAL

230 volt AC

50 hertz, 2 wire (plus ground), 1-phase, 30 amp wiring required

Electrical cord not provided

#### VENTILATION

The smoker must be vented in accordance with the Owner's Manual and the installation must comply with all relevant local and national codes and in a manner acceptable to the authority having jurisdiction.

WEIGHT - 300 lbs. (136 kg) - Standard smoker

SHIPPING (crated) - 450 lbs. (204 kg), Class 100, ISPM-15 compliant

27"L x 37"W x 67"H (686 x 940 x 1702mm)